



## QUALITY

RMP rubber molded bumpers are made in the USA from 100% cured rubber. They are made for durability and a clean, attractive look.

## PROTECTION

Chemical-Resistant Hi-Impact compact design will not warp, rust, rot or harden. Long lasting protection year-round for all-weather applications.

## 3RD PARTY TESTED

Testing done by:  
ARDL (Akron Rubber Development Laboratory, Inc.)  
ARDL is an A2LA ISO 17025 Accredited Testing Laboratory.  
Certificate # 255.01 & 255.02 ISO 9001:2008 Registered.

## MANUFACTURER

Roll-Tech Molding Products, LLC  
866-431-4515  
www.roll-tech.net

# RMP Rubber Bumper *BUMPR-TB20*



Figure 1: RMP BUMPR-TB20 Rubber Bumper

## INSTALLATION

- Pre-drilled, countersunk mounting holes for easy installation.
- 5/8" anchor bolts are mounted through pre-drilled holes.
- Perfect protection for trailers, trucks and wall defense.
- Provides maintenance free in-plant wall protection from forklifts and other material handling vehicles.

## TEST QUALIFICATIONS

- Tensile Strength ASTM D2240-05
- Durometer ASTM D412
- Compression Set ASTM D395-16
- Rebound ASTM D2632-15
- Compressive Deflection ASTM D695-15

-----●  
*\*ASTM 1170 changed to ASTM F104\*  
in 1962 & no longer supports  
compressibility & recovery standards.*  
-----●

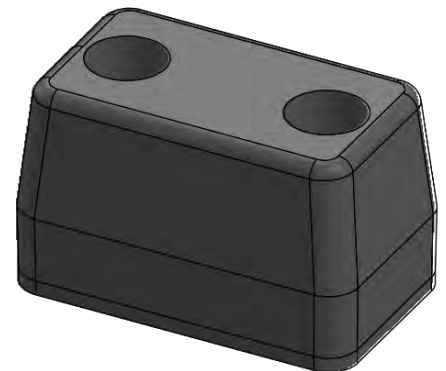
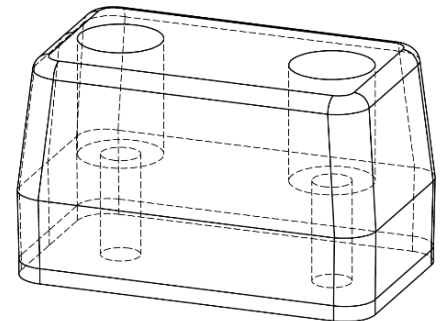

Figure 2: RMP BUMPR-TB20 2-D Drawings



**BUMPR-TB20**  
Rubber Bumpers  
MADE IN USA



## TECHNICAL SPECS

Bolt Holes ID: 5/8"  
 Width: 3-1/2"  
 Length: 5-7/8"  
 Height: 3-9/16"  
 Weight: 2.5 Lbs

## MANUFACTURING SOLUTIONS

Roll-Tech is a privately held company located in Hickory, NC.

We continue to pioneer the materials industry through the innovation of new products for 20 years & counting.

Our rubber compression molding technology was developed in Europe & was brought to the USA. Now, that technology is used to design, test, & manufacture a diverse line of molded products. A Roll-Tech product is durable, supports heavy loads, sustainable & MADE IN AMERICA.

## INFO

For more information on our products or services please visit us on the web at:  
[www.roll-tech.net](http://www.roll-tech.net)

# Product Features and Test Results

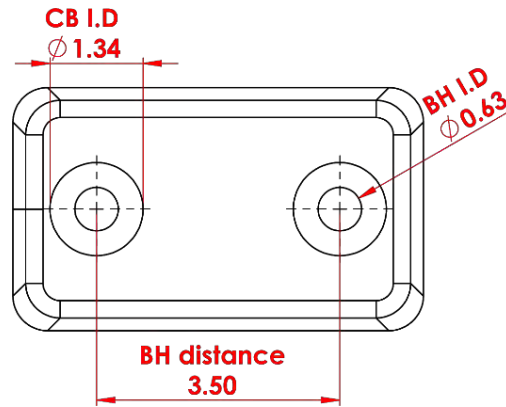

Figure 3: RMP BUMPR-TB20 2-D (Top View)



## COMPRESSION SET - 18%

- Material shows stronger elastic network than other bumpers on the market.

## BAYSHORE REBOUND - 35%

- Material shows similar rebound to other bumpers on the market.

## COMPRESSIVE DEFLECTION (LOAD TO BREAK) - 112,300 lbf

- Material shows similar compressive deflection to other bumpers on the market.

**RMP Bumpers Are An Excellent Inexpensive Alternative To Market Materials They Are Field Tested & Made Ready To Use.**

## TENSILE STRENGTH TO BREAK - 470 psi

- Similar tensile strength to other bumpers on the market.

## HARDNESS - 71 ShoreA

- Similar hardness to other bumpers on the market.

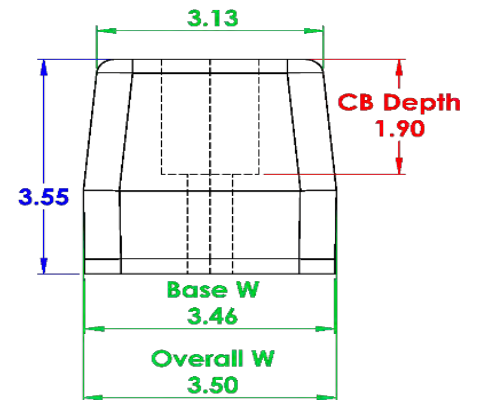
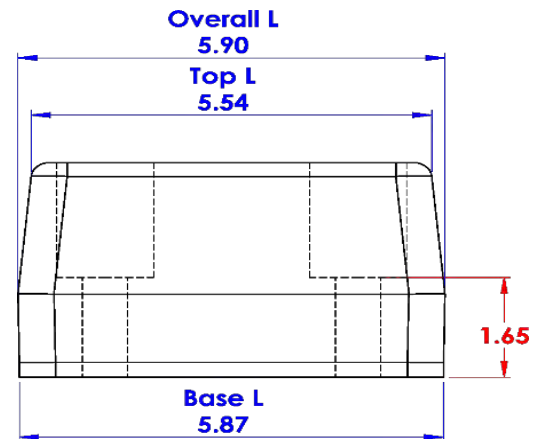

Figure 4: RMP BUMPR-TB20 2-D (Side View)



243 Performance Dr. SE  
 Hickory, NC 28602  
 Phone 866.431.4515  
 Fax 828.431.4515